

BLDC4244

Brushless Dc Motor

Application : Drill & Screwdriver

用途：電動工具

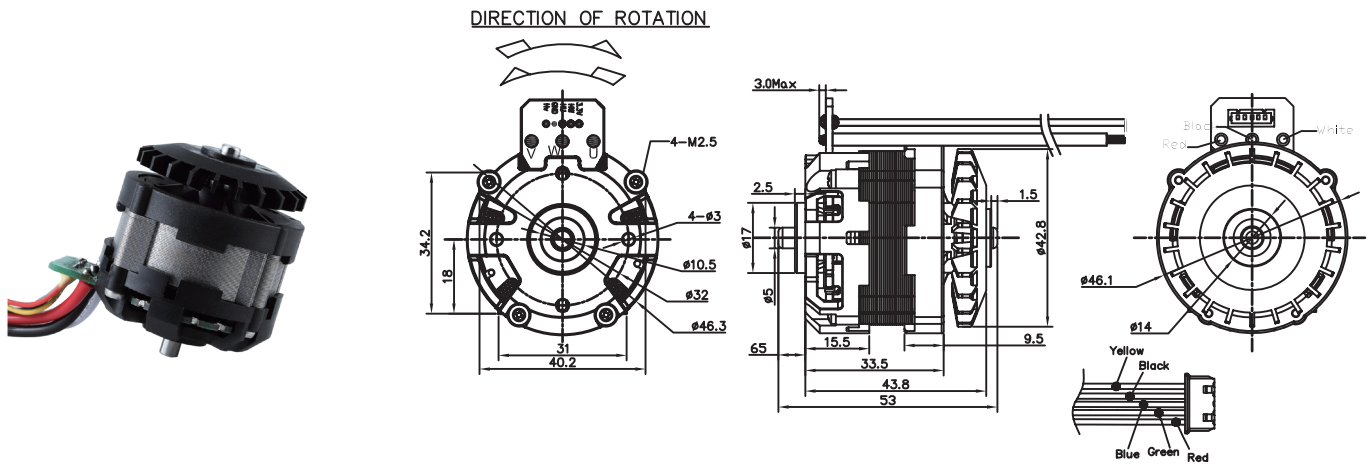

WEIGHT : 200g(APPROX)

	wire from the motor			wire from the hall				
definition of the wire	U	V	W	+5V	GND	HU	HV	HW
color of the wire	Red	White	Black	Red	Black	Blue	Yellow	Green

MODEL	VOLTAGE		NO LOAD		AT MAXIMUM EFFICIENCY					STALL			
	OPERATING RANGE	NOMINAL	SPEED	CURRENT	SPEED	CURRENT	TORQUE	OUTPUT	EFF	CURRENT	TORQUE		
			rpm	A	rpm	A	g-cm	mN-m	W	%	A	g-cm	mN-m
BLDC4244A1W0	-----	18.0V CONSTANT	20500	1.74	17986	12.55	906	88.82	167.35	80	95.54	7645	749.51
BLDC4244A1W0	-----	18.0V CONSTANT	26200	3.30	22371	18.75	1028	100.78	236.17	75	117.33	7570	742.16

馬達的出軸長度及性能參數，EMC 對策可依客人要求做調整，詳情可詢問相關業務人員。
Please inquire your sales representative for output, performance and EMC solution.

