

Application : Drill & Screwdriver 、 Motorized Toy

用途：電動工具、玩具

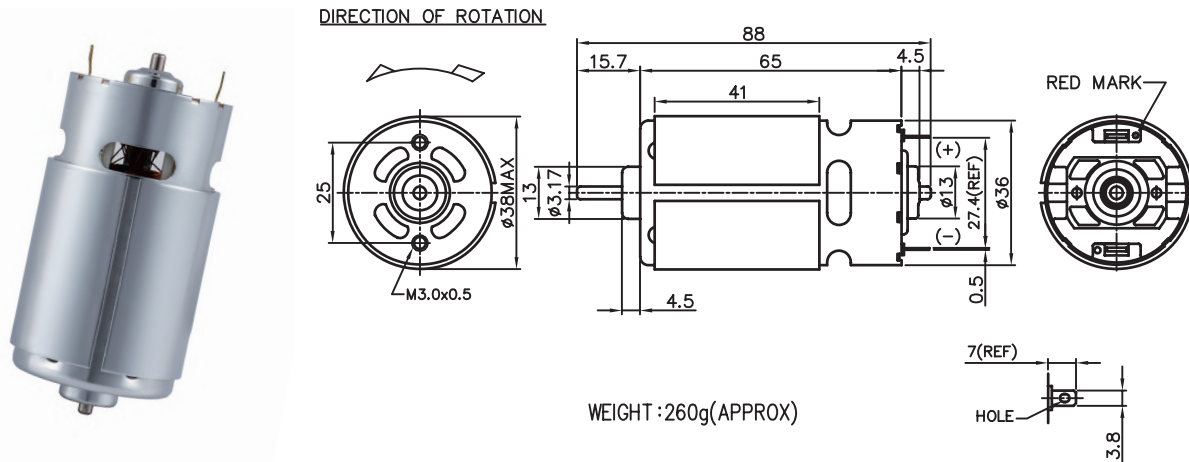

MODEL	VOLTAGE		NO LOAD		AT MAXIMUM EFFICIENCY						STALL		
	OPERATING RANGE	NOMNAL	SPEED rpm	CURRENT A	SPEED rpm	CURRENT A	TORQUE g-cm	TORQUE mN-m	OUTPUT W	EFF %	CURRENT A	TORQUE g-cm	TORQUE mN-m
ND3SFN-4565-R	6.0 - 24.0	12.0V CONSTANT	6700	0.50	5800	2.60	367	35.98	22.00	71	17.91	2927	286.96
ND3SFN-4570-R	6.0 - 24.0	12.0V CONSTANT	6200	0.30	5400	2.17	342	33.53	19.08	74	17.02	3034	297.45
NC3SFN-6035-R	6.0 - 18.0	12.0V CONSTANT	12000	1.00	10700	5.63	465	45.59	51.50	76	51.36	4557	446.76
NC3SFN-7522-R	6.0 - 12.0	12.0V CONSTANT	19500	1.40	17500	9.42	466	45.69	83.95	75	81.60	4603	451.27

馬達的出軸長度及性能參數，EMC 對策可依客人要求做調整，詳情可詢問相關業務人員。
Please inquire your sales representative for output, performance and EMC solution.

