

Application : Central Locks

用途：中控鎖

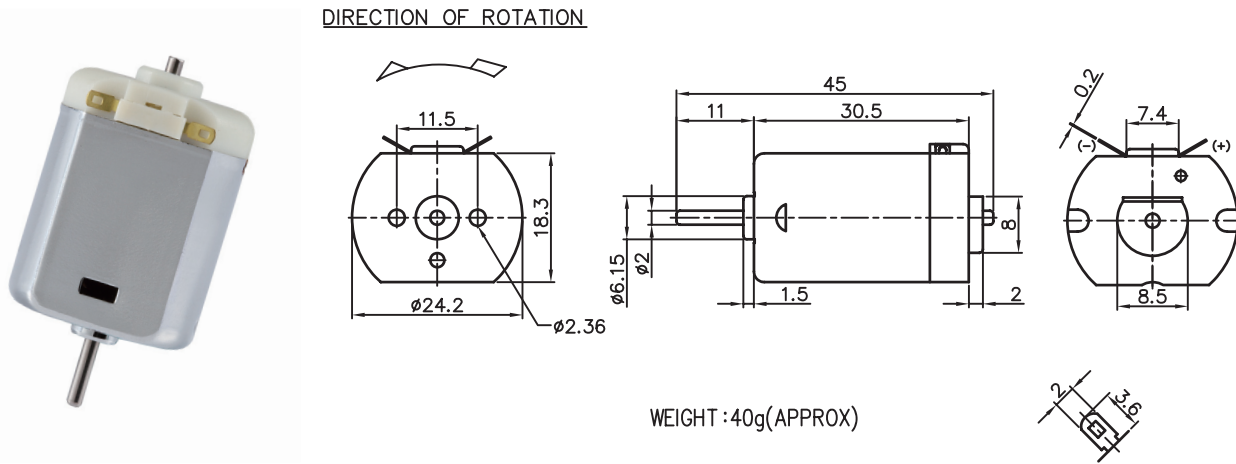

MODEL	VOLTAGE		NO LOAD		AT MAXIMUM EFFICIENCY						STALL		
	OPERATING RANGE	NOMNAL	SPEED	CURRENT	SPEED	CURRENT	TORQUE	OUTPUT	EFF	CURRENT	TORQUE		
			rpm	A	rpm	A	g-cm	mN-m	W	%	A	g-cm	mN-m
UC-280-20125-NR	3.0 - 9.0	6.0V CONSTANT	10000	0.14	7600	0.52	19	1.86	1.51	49	2.28	110	10.78
UC-280P-19160-NR	6.0 - 12.0	12.0V CONSTANT	11500	0.15	9000	0.57	46	4.51	4.30	63	2.90	250	24.51
UC-280P-12285-NR	6.0 - 24.0	24.0V CONSTANT	13000	0.09	10100	0.37	49	4.80	5.19	59	1.54	255	25.00
UC-280P-16175-NR	6.0 - 12.0	12.0V CONSTANT	10100	0.09	8100	0.45	37	3.63	3.13	61	1.94	202	19.80

馬達的出軸長度及性能參數，EMC 對策可依客人要求做調整，詳情可詢問相關業務人員。
Please inquire your sales representative for output, performance and EMC solution.

